

Programm 063 - Maßskizzen

WTA 0805 + SET 387S

WTA 0805 + SET 381S

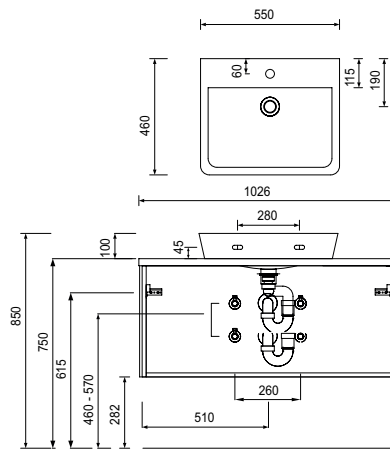
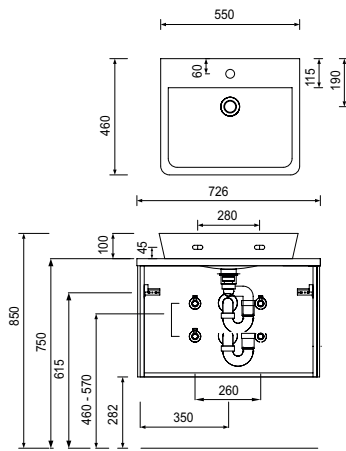

WTA 0805 + SET 382S

WTA 0805 + SET 3817

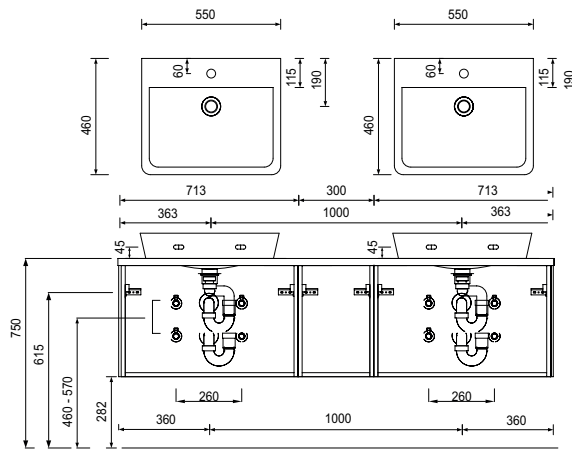
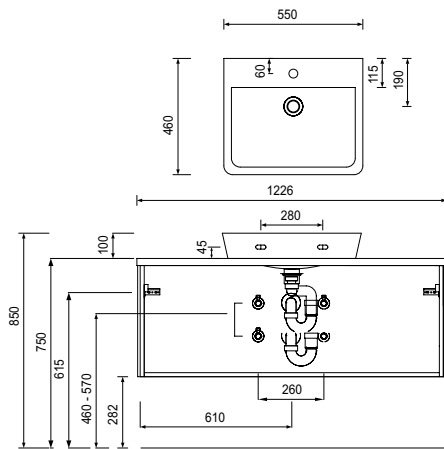

WTA 1104 + SET 387S

WTA 1104 + SET 381S

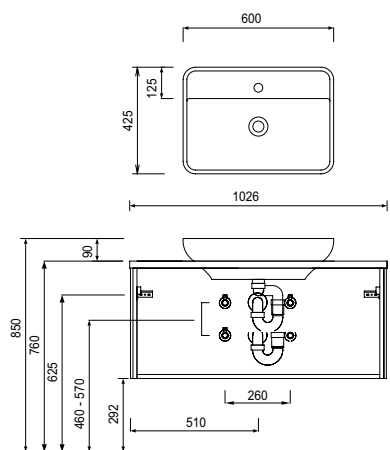
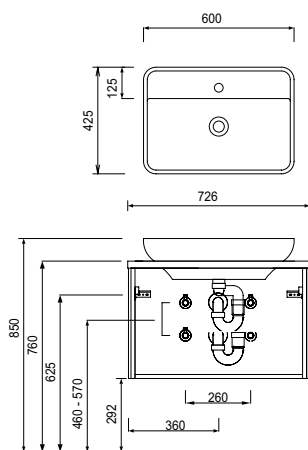

Toleranzen:

Die Maßtoleranzen (+/- 5mm) und Ebenheitstoleranzen (DIN 18202) unterliegen den üblichen materialspezifischen Toleranzen für Bauwerkstoffe, anlehndend an die DIN 18202.

Programm 063 - Maßskizzen

WTA 1104 + SET 382S

WTA 1104 + SET 3817

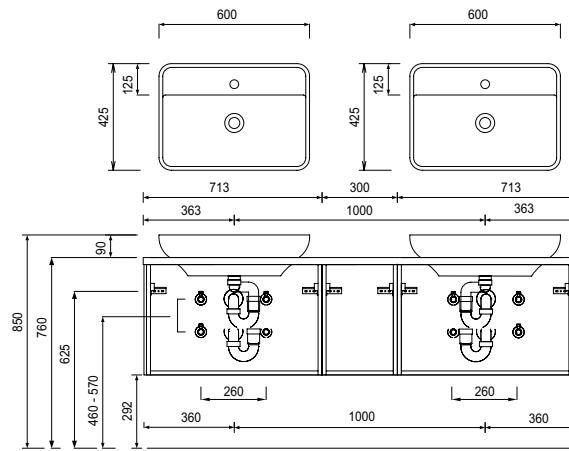
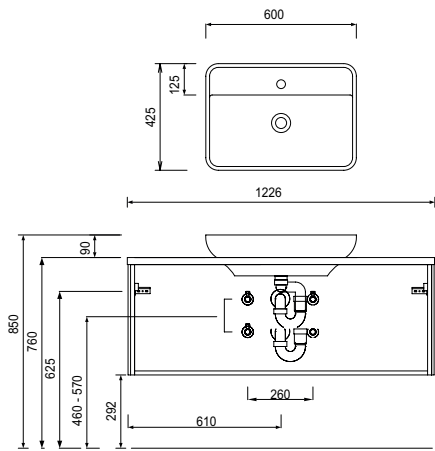

Elektroanschlüsse für Spiegelemente

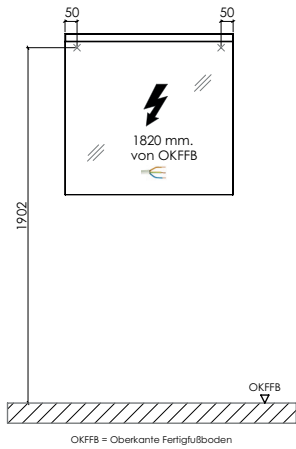

Toleranzen:

Die Maßtoleranzen (+/- 5mm) und Ebenheitstoleranzen (DIN 18202) unterliegen den üblichen materialspezifischen Toleranzen für Baustoffe, anlehnd an die DIN 18202.